



WHEEL-TECH



Carrellino pivotante porta ruota e attrezzatura.

Wheel-tech è un pratico carrellino dotato di 4 ruote con basamento pivotante di 360°, di pedale di blocco/sblocco rotazione e pedale freno di stazionamento.

Wheel-tech è equipaggiato con 2 o 5 cassetti con chiusura a chiave, poggia ruota con blocco regolabile per pneumatici da 180 a 340 mm, pratici vani porta bombolette, cassetta porta minuteria e 2 tubi spiralati per erogazione aria compressa.

Wheel-tech si muove in modo agevole e rapido grazie all'ergonomica maniglia e quindi può essere ubicato velocemente nella posizione di lavoro scelta dall'operatore.



Wheel and equipment carrier trolley with pivoting wheels.

Wheel-tech is a practical trolley featuring 4 wheels with 360° pivoting base, equipped with rotation locking/unlocking pedal and parking brake pedal.

Wheel-tech is equipped with 2 or 5 drawers with key-operated lock, wheel support with adjustable blocking device for tyres measuring from 180 to 340 mm, practical cylinder compartments, hardware drawer and 2 spiral pipes for dispensing compressed air. Wheel-tech can be moved rapidly and easily thanks to the ergonomic handle and can therefore be placed quickly in the working position required by the operator.



Chariot pivotant porte-roue et équipement.

Wheel-tech est un chariot pratique doté de 4 roues, avec une base pivotante à 360° munie d'une pédale de blocage/débloqué de rotation et d'une pédale de frein de stationnement.

Wheel-tech est équipé de 2 ou 5 tiroirs verrouillables, d'un repose-roue avec bloc réglable pour des pneus de 180 à 340 mm, de pratiques compartiments porte-bombes aérosol, d'un petit tiroir porte-pièces métalliques et de 2 tubes spiralés pour la distribution d'air comprimé.

Wheel-tech se déplace simplement et rapidement grâce à sa poignée ergonomique et il peut être placé rapidement dans la position de travail choisie par l'opérateur.



Schwenkbarer rad- und gerätewagen.

Wheel-tech ist ein praktischer wagen mit 4 rädern, einem um 360° schwenkbaren untergestell mit pedal zur sperre/freigabe der drehung und einer feststellbremse mit pedal.

Wheel-tech ist mit 2 oder 5 abschliessbaren schubfächern versehen, einer radablage mit verstellbarer blockierung für reifen von 180 bis 340 mm, praktische flaschenhalter, einem schubfach für kleinteile und 2 spiralschläuche für die druckluftabgabe.

Wheel-tech kann dank des ergonomischen griffs bequem und schnell gefahren und daher schnell in die vom bediener gewünschte arbeitsposition gebracht werden.



Carro pivotante porta-rueda y equipo.

Wheel-tech es un práctico carro provisto de 4 ruedas con basamento pivotante a 360°, provisto de pedal de bloqueo/desbloqueo de la rotación y pedal de freno de estacionamiento.

Wheel-tech está equipado con 2 o 5 cajones con cierre con llave, apoyo para la rueda con bloqueo regulable para neumáticos de 180 a 340 mm, prácticos compartimentos porta-aerosoles, cajón para piezas pequeñas y 2 tubos espirales para el suministro de aire comprimido.

Wheel-tech se desplaza de manera fácil y rápida gracias al asa ergonómica, por lo que puede colocarse rápidamente en la posición de trabajo elegida por el operador.

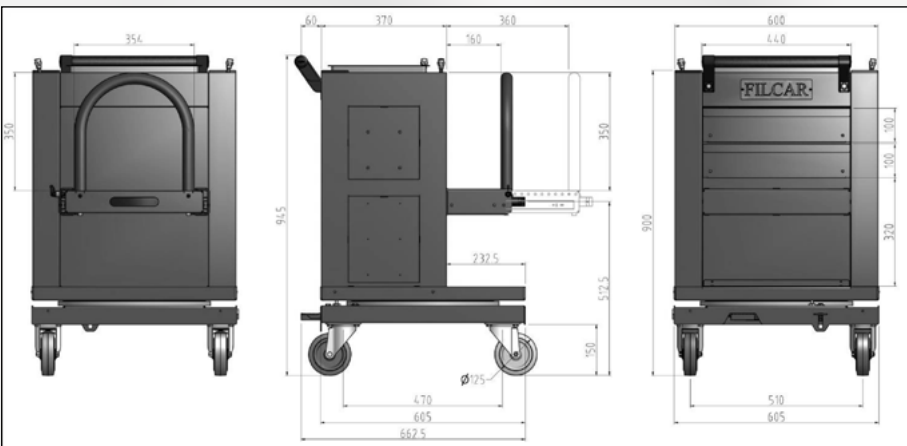
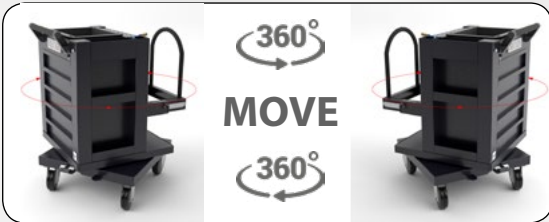



WHEEL-TECH/2

Modello con 2 cassetti - Model with 2 drawers - Modèle avec 2 tiroirs - Modell mit 2 Schubladen - Modelo con 2 cajones.



WHEEL-TECH/5

Modello con 5 cassetti - Model with 5 drawers - Modèle avec 5 tiroirs - Modell mit 5 Schubladen - Modelo con 5 cajones.





Scan me

FILCAR S.p.A.

via G. Balla, 18 - 42124
REGGIO EMILIA
ITALY

Tel. +39-0522-941881
Fax. +39-0522-942291
Tel. +39-0522-941167
Fax. +39-0522-494035
www.filcar.eu

FILCAR S.A.R.L.

71, Rue de Malacombe
38070 - ST. QUENTIN
FALLAVIER - LYON
FRANCE

Tel. +33-0474-944064
Fax. +33-0474-942931
www.filcar.fr

WHEEL-TECH-FLYER-EU-04/2019

www.filcar.eu